

## USDA-ACCEPTED AIRSWEEP® SYSTEMS

Ideal for applications requiring sanitary equipment or frequent cleaning

### CLEANS INTERIOR SURFACES • ELIMINATES RATHOLES, BRIDGING & MATERIAL BUILDUP

The AirSweep® material activation system delivers on-demand product flow, eliminates material buildup and enhances batch uniformity.

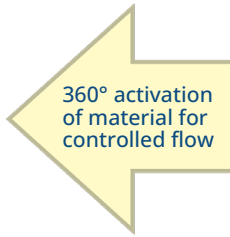

Each AirSweep nozzle directs a high-pressure, high-volume, 360-degree burst of compressed air or inert gas along the inside walls of process equipment or vessels, breaking friction to lift and sweep stalled material back into the flow stream. The patented nozzle design ensures an immediate reseal after each pulse to eliminate material feedback.

Sequenced pulsing of strategically-positioned AirSweep units activate bulk material to produce a first-in, first-out (FIFO) controlled flow.

## PRODUCT HIGHLIGHTS

- Designed and fabricated according to sound USDA sanitary design principles
- Flanged connections for quick installation or removal from mounting and process connections
- Quick and easy removal/disassembly with simple hand tools
- All surfaces resistant to corrosive products and cleaning/sanitizing chemicals
- Manufactured from high-grade 316 Stainless Steel for long service life (material certificates available upon request)
- Energy efficient – uses plant air
- Products are serialized for traceability



Performance, per unit*		
Model	Material Activation Area (diameter on a flat surface)	Approx. Air Consumption*
USDA-185	Up to 8 feet (2.44 m)	2.15 scf (.06 m³) @ 90 PSI (6.21 Bar)

Based on the AirSweep USDA Sanitary Pulse Valve (42Cv). Material activation area can be affected by the type of material and the shape or surface of the vessel.

\*Average in 75 lb/ft³ material; 250 millisecond air pulse.

Easily retrofits to spray dryers, mixers, silos, hoppers, ducts, blenders, troughs, sifters, chutes, cyclones or ANY bulk powder process requiring sanitary equipment.

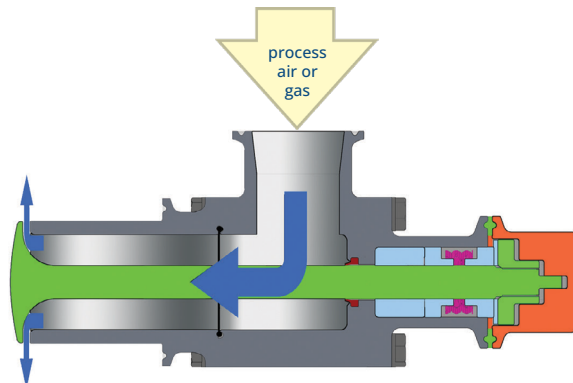

Cleans interior vessel walls and is highly effective for flushing material from mixers, blenders, cyclones and spray dryers.

Specifications subject to change without notice.

Contact us for a detailed AirSweep® System proposal, engineered specifically for your application.

# TYPICAL AIRSWEEP® USDA-185 SYSTEM

A typical AirSweep® material activation system consists of strategically-located AirSweep units, high-flow AirSweep Pulse Valves, electronic sequence controller and air receiver.

The average AirSweep System uses less than 10 cfm of compressed air or gas, making it energy and cost efficient.

If you have any questions regarding the AirSweep System, call 860-928-6551, or email us at [Sales@AirSweep.com](mailto:Sales@AirSweep.com)

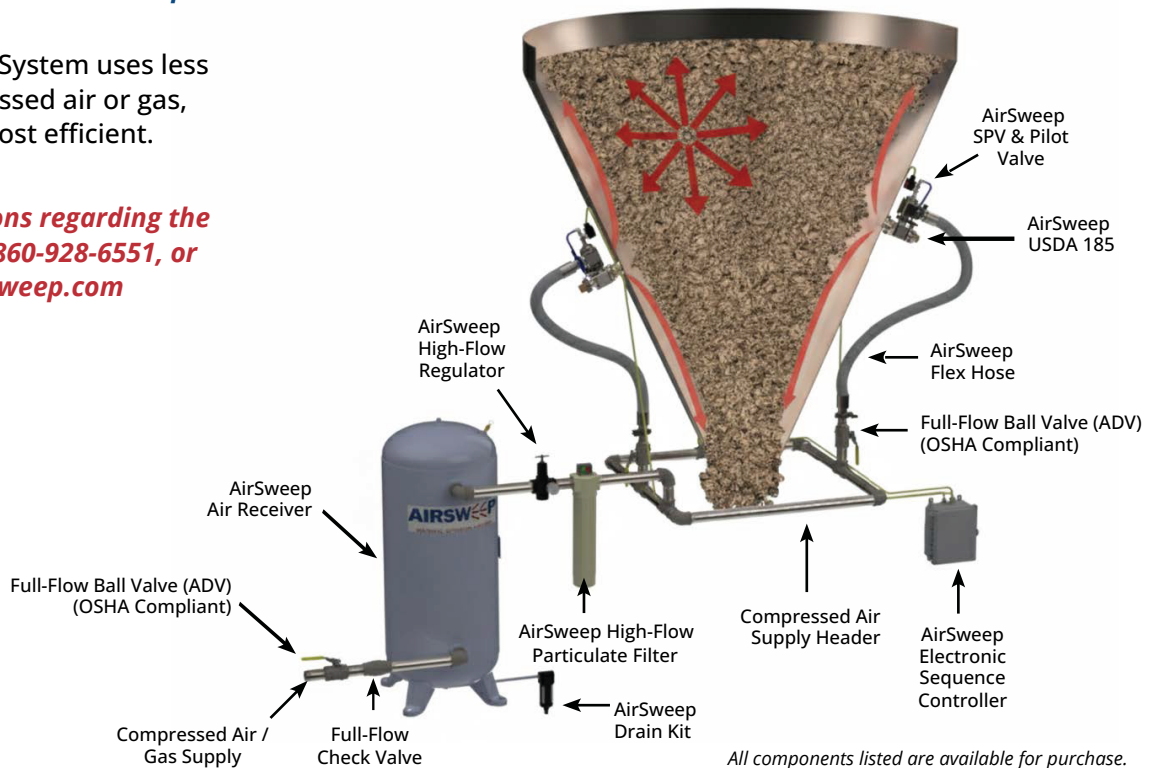

All components listed are available for purchase.

## Typical AirSweep System Components

AirSweep	Model USDA-185 (ATEX Rated)
Sanitary Pulse Valve	Delivers rapid, high-volume pulse of compressed air/gas to the AirSweep
Flex Hose Assembly	Connects the AirSweep Pulse Valve to hard-piped header loop
Full-flow Ball Valve	Isolation valve for individual AirSweep Valve Assemblies. The use of auto drain valves (ADV) is highly recommended in pneumatic applications for safety and OSHA compliance
High-flow Particulate Filter	Point-of-use particulate filtration enhances life of system components by removal of in-line contaminants
80-gallon Air Receiver	Compressed air reservoir ensures instantaneous volume for system (Additional sizes in stock and available upon request)
High-flow Regulator	Regulates compressed air supply within 60-90 PSI (4.14-6.21 Bar) for proper AirSweep operation
Full-flow Check Valve	Ensures one-way flow to the system
Full-flow Ball Valve	System shut-off
Electronic Sequence Controller	Controls sequenced pulsing of AirSweep system; adjustable for any process (NEMA 4X and NEMA 7/9 enclosed timers are in stock.)

**Important Note:** For safety and future flexibility during installation and maintenance, we recommend instituting the use of unions as needed (also available for purchase).

Contact us for a detailed AirSweep® System proposal, engineered specifically for your application.

# USDA-185 MOUNTING COUPLING INSTALLATION

## USDA MOUNTING COUPLING INSTALLATION (WELD TO VESSEL)

1. Drill or cut a hole in the vessel wall. Recommended hole size for USDA-185 mounting coupling: 2.578" (65.48 mm)
2. Align coupling flush with the inside of the vessel wall. Insert the heat sink to protect the mounting coupling from warping, and stitch weld to evenly distribute heat to the exterior of the wall.\* (See Figure 1 below)
3. Install clamp gasket to the inside groove of the mounting coupling flange. (See Figure 2 on page 4)
4. Push AirSweep fully into mounting coupling, ensuring clamp gasket is tightly sandwiched between them. (See Figure 2 on page 4)
5. Install tri-flange clamp around AirSweep and mounting coupling flange, and hand-tighten until snug. (See Figure 3 on page 4)
6. Install clamp gasket to the inside groove in the rear AirSweep flange.
7. Position AirSweep USDA Sanitary Pulse Valve to match the AirSweep USDA-185 air inlet, with the gasket sandwiched between the two parts.
8. Install the tri-flange clamp around Air Inlet flange and hand-tighten until snug. (See Figure 3 on page 4)

### NOTES:

- On sharply curved vessel walls, the front surface of the mounting coupling may extend slightly into the vessel at the top and bottom (12:00 and 6:00 positions), and should be flush at the sides (3:00 and 9:00 positions).
- For maximum effectiveness, use a direct connection between the Air Inlet and AirSweep USDA Sanitary Pulse Valve, with no additional pipe nipples or fittings. If additional pipe length is required, consult with the AirSweep application engineering team to design the most efficient system layout between the AirSweep USDA Sanitary Pulse Valve Air Outlet and AirSweep USDA-185 Air Inlet.

① **\*Welding procedure, when allowed, requires tacking and the use of a heat sink to avoid warping of Mounting Coupling.** Welding should be done in accordance with the American Welding Society (AWS) standards as supported by ASME (American Society of Mechanical Engineers)

FIGURE 1

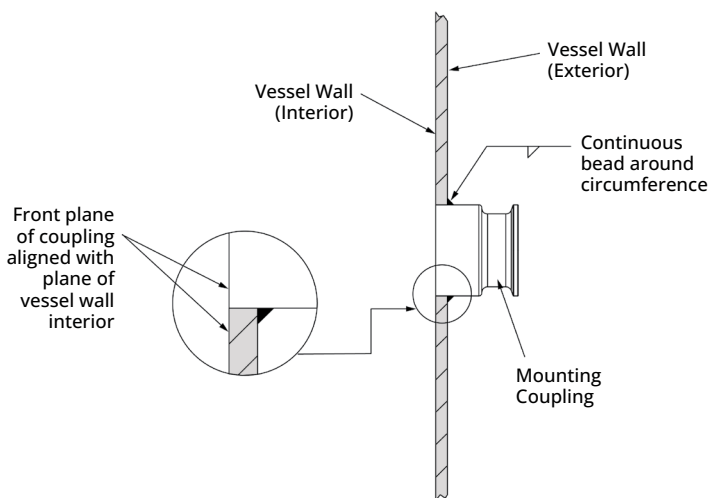

USDA-185 HEAT SINK  
(HS-185A-TRI & HS-185C-TRI)

Available in Aluminum & Copper

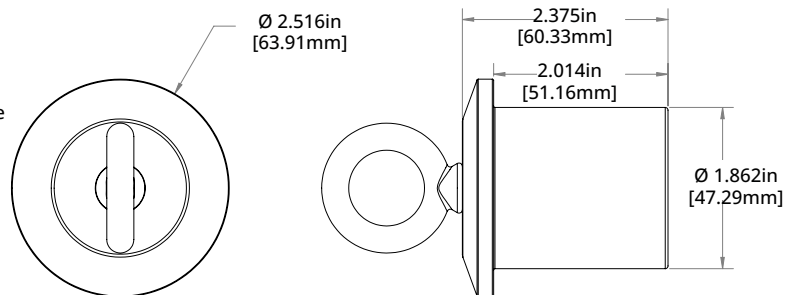

Unit is welded and polished on both internal and external surfaces to eliminate gaps that could harbor microbial contamination.

Contact us for a detailed AirSweep® System proposal, engineered specifically for your application.

# USDA-185 MOUNTING COUPLING INSTALLATION

**FIGURE 2**

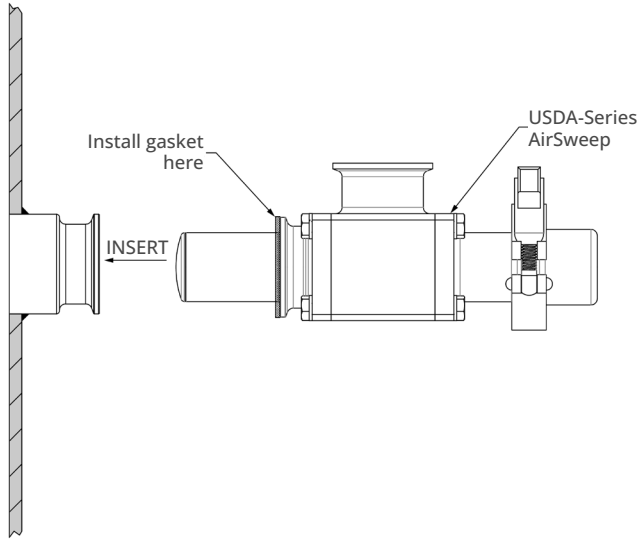

**FIGURE 3**

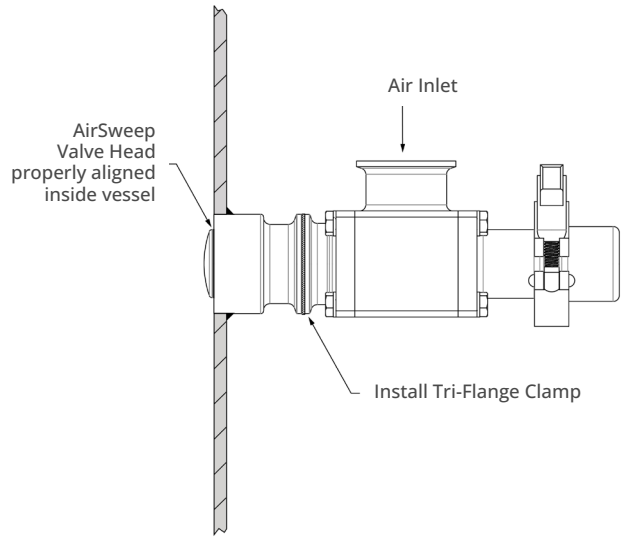

# USDA-185 MODEL SPECIFICATIONS

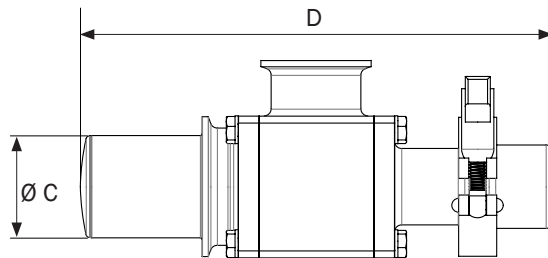
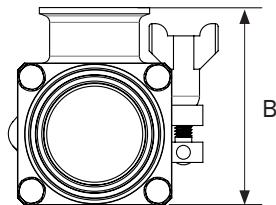
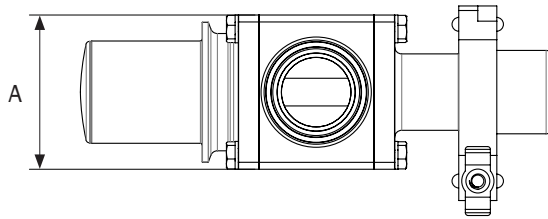
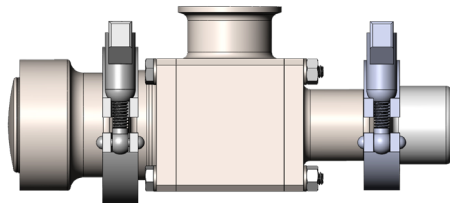

Mounting Coupling

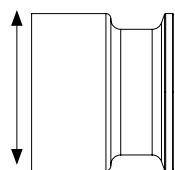

	Main Unit				Mounting Coupling		
Model	A	B	Ø C	D	Ø E	F	Weight
USDA-185	2.78" (70.61 mm)	3.54" (89.62 mm)	1.84" (46.74 mm)	8.50" (215.90 mm)	2.52" (64.00 mm)	1.89" (48.00 mm)	8.16 lb (3.71 kg)

*Specifications subject to change without notice.*

Contact us for a detailed AirSweep® System proposal, engineered specifically for your application.

# USDA BEST FLOW AID FOR SANITARY PROCESSES

Multi-national food and pharmaceutical manufacturers trust AirSweep USDA-accepted systems to promote material flow and protect product quality and safety. Find out why it is the best flow aid for sanitary processes.

## WATCH HOW IT WORKS

[Click the link](#) to watch a short video on the USDA-accepted AirSweep's features and how it can benefit your business.

## AIRSWEEP VS OTHER FLOW AIDS

	AirSweep	Fluidizers	Vibrators
<b>Material Activation</b>	Works on moist, sticky or tough materials	Only works on light powders like flour	Can compact some materials
<b>Risk for Contamination</b>	<ul style="list-style-type: none"><li>• Meets all sanitary design requirements</li><li>• No residue – sweeps vessel walls clean</li></ul>	Components can degrade and contaminate the mixture	Leaves residue on vessel walls
<b>Cleaning and Maintenance</b>	Can be quickly removed with simple hand tools for frequent cleaning	Difficult to remove and clean	Difficult to remove and clean
<b>Operating Costs</b>	Timed and precise air pulses efficiently use energy and plant air	Runs continuously, wasting resources while moving minimal material	<ul style="list-style-type: none"><li>• Uses more energy</li><li>• Can damage vessels</li></ul>

## PROVEN BENEFITS

### REDUCED FLUSH TIME, LABOR AND COSTS

A large [U.S. manufacturer of ingredients and flavor products](#) used to manually flush the ribbon blenders between batch runs. After switching to AirSweep, they **reduced material flush by 62%, manual labor by 52%, and saved \$200,000 on material reduction alone.**

### SHORTENED CLEANING TIMES

An [infant formula manufacturer](#) produces several formulations in the same processing and packaging lines. They used AirSweep during production and between batch runs to clear powder buildup from vessel walls. **“We went from 40 hours to 10 hours in cleanup time,”** said the Company's Associate Director for Process Technology Application and Productivity.

### HIGHER PRODUCTION AND LOWER ENERGY COSTS = ROI

A leading [candy manufacturer](#) struggled with cocoa bridging and ratholing in their hoppers. Workers had to scrape the vessels every three days, often ending up covered in material spills.

They tested multiple flow aids, but only AirSweep delivered real results. **“It has a much stronger air pulse than the bin aerators or fluidizers we used before,”** said the coatings manager. “The air moves the powder down in a wide column so it doesn't cling to the walls.”

With AirSweep, the plant eliminated manual scraping, **added two extra production shifts, and even reduced plant air use**—recovering the system's cost in just two months, a quick return on investment (ROI).

Contact us for a detailed AirSweep® System proposal, engineered specifically for your application.