

Micro-controlled, Field-adjustable, Multi-setpoint Speed Monitor

The **PROX 120 Proximity Switch** is a non-contacting speed sensing device which converts pulses from a ferrous target to an electrical signal. The speed monitor utilizes a microcontroller and proprietary internal software to precisely monitor the RPM rate of the rotating ferrous target(s). Time between pulses is compared to application appropriate, user-defined settings.

The **PROX 120** is packaged in a NEMA 4/5 enclosure with a transparent Lexan™ cover for dust and moisture protection.



Features:

- Large sensing range:
 - 6 – 30,000 RPM based on 1 pulse per revolution
 - 1 – 7,500 RPM based on 4 pulses per revolution
 - 0.1 – 3000 RPM based on 60 pulses per revolution
- Simultaneous speed monitoring:
 - 20-99% Under Speed / 101-199% Over Speed
- Easy to program and field adjustable
- 4-character alphanumeric LED display shows alarm status in low light
- Non-contact sensing – not directly coupled to a shaft
- Epoxy-coated cast aluminum housing with Lexan™ cover
- Proximity sensor features:
 - 10-30 VDC NPN M18mm Shielded N.O.
 - 500 Hz, 6' (1.83 m) cable
 - 0.315" (8.0 mm) sensing distance
 - Will pick up any ferrous material – magnet not required

| PROX 120 | |
|-------------------|---|
| Conduit Entry | Power/signal wires: 1/2" NPT PROX wire: 3/8" |
| Temperature Range | -40° to +158° F (-40° to +70° C) |
| Voltage Options | 120/240 VAC or 24 VDC |
| Supply Current | 100 mA maximum |
| Output | Single Pole 10-A SPDT Relay 250 VAC, UL/CSA |
| Frequency Range | Controller: 0.1 Hz to 2500 Hz Sensor: 500 Hz |
| Memory | Nonvolatile, 10-year retention |

Application Considerations:

- Verify PROX 120 is compatible with voltage, process, temperature, construction and area classification.
- Sensor distance (0.315" [8.0 mm]) must be correct, secure and maintained for consistent operation.
- Proximity sensor detects the presence and absence or distance of metals, and should be located where the rotational process can be appropriately monitored.
- Install PROX 120 according to National Electrical Code and/or local standards.
- Seal all conduit entries to the enclosure.
- Close transparent cover immediately upon program completion to minimize exposure to dust and weather.
- Do not use this device in explosive areas or locations classified as hazardous. The PROX 120 is not designated for NEMA 7, 8, 9 or 10 locations.

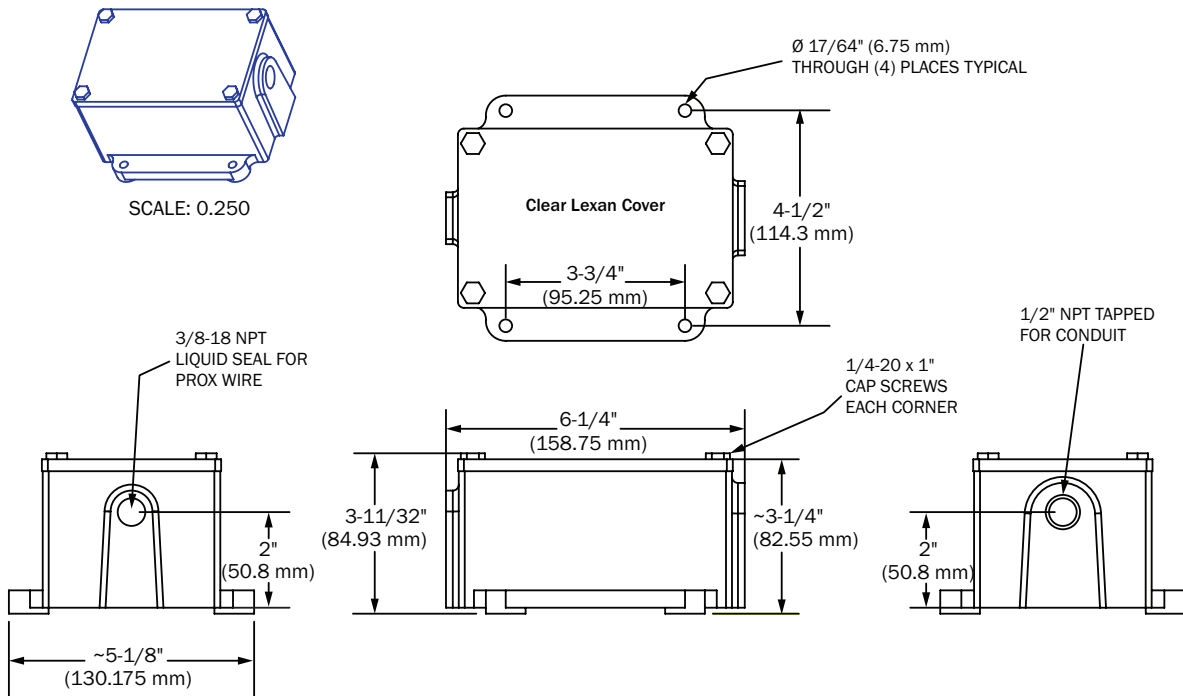

Speed Conversions and Range Calculations

Operating range and conversion calculations from Hz to RPM are dependent upon the number of pulses per each revolution. With one pulse per revolution, 1 Hz is equal to 60 RPMs (one pulse per second X 60 seconds per min = 60 RPMs). Under-speed limit of 0.1 Hz equates to 6 RPMs.

Pulses may be manipulated by adding or subtracting vanes, bolt heads, spokes, holes, etc. in the monitoring device wheel or hub. The inductive proximity sensor detects ferrous (iron) metals best, but can also sense other metals. Sensing distance may vary depending on the metal and pulse vane configuration. The PROX 120 is supplied with a 500 Hz sensor.

Programming Specifications

HSPD & LSPD: High and Low Speed alarm settings are percentage variables based on the normal calibrated running speed of 100%. The Under-Speed value range is 20-99% of Full Speed, while Over-Speed is 101-199%. Values outside this range will not be accepted.

Start-Delay: Programmable from 0 to 255 seconds, activated by initial power applied to the device. Delay will not re-occur until power is turned off and back on.

Programming Setup: INCR (Increment) and ENTER pushbuttons, four character alphanumeric LED display, as well as STATUS and RELAY LEDs.

Program Settings: SDLY (Start-up Delay), LSPD and HSPD, RYFS (Relay Failsafe Condition), ADLY (Relay Energize Delay), CDLY (Relay De-energize Delay), OKAY (Condition Indicator), ERR 0-9 (Troubleshooting Info).

Relay Reaction Time: Independently programmable from 0 to 255 seconds. Energized ADLY and de-energized CDLY.

Alarm Indicators: The 4-character alphanumeric LED display provides <MIN low-speed alarm and >MAX over-speed display for alarm condition and ERROR codes for diagnostics. GREEN status LED provides pulse indication, RED relay LED indicates energized or de-energized condition of the relay.