

## INDUCTIVE PROXIMITY SPEED SWITCH

### DESCRIPTION

The Proximity Switch is a non-contacting speed sensing device which converts pulses from a ferrous target to an electrical signal. It is a micro-controlled, field adjustable, multi-setpoint speed monitor, with a 4 character alpha-numeric visual indication and relay output. Features include simultaneous Over / Under speed monitoring, programmable relay action, and non-contact sensing. The Prox 120 is packaged in a NEMA 4/5 enclosure with a transparent Lexan™ cover for dust and moisture protection.

### OPERATING THEORY

The speed monitor utilizes a microcontroller and proprietary internal software to precisely monitor the RPM rate of the rotating ferrous target (s). Time between pulses is compared to application appropriate, user defined settings.

### ADVANTAGES & SPECIFICATIONS

- ✓ Huge Sensing Range      6.0 — 30,000 RPM based on 1 pulse per revolution  
1.0 — 7,500 RPM based on 4 pulses per revolution  
0.1— 3000 RPM based on 60 pulses per revolution
- ✓ Under & Over Speed    20-99% for Under Speed / 101-199% for Over Speed
- ✓ Programmable            Easy to program • field adjustable
- ✓ LED Readout             4 Character display shows alarm status in low light
- ✓ Durable Housing         Epoxy coated aluminum housing • Lexan™ cover
- ✓ Conduit Entry            1/2" NPT for power/signal wires • 3/8" for Prox wire
- ✓ Non-Contacting         Not directly coupled to a shaft
- ✓ Proximity Sensor       Includes 10-30VDC NPN M18mm Shielded N.O., 500 Hz, 6' cable • 0.315" sensing distance • Will pick up any ferrous material — magnet not required.
- ✓ Temperature Range    -40 to +158°F (-40 to +70°C)
- ✓ Memory                  Nonvolatile, 10-year retention
- ✓ Voltage Options         120/240 VAC or 24 VDC
- ✓ Supply Current         100mA Maximum
- ✓ Output                    Single Pole 10-A SPDT Relay • 250 VAC • UL/CSA
- ✓ Frequency Range        0.1 Hz to 2500 Hz Controller / 500 Hz Prox Sensor



### APPLICATION CONSIDERATIONS

- Verify Prox unit is compatible with voltage, process, temperature, construction and area classification.
- Sensor distance must be correct, secure and maintained for consistent operation.
- Proximity sensor detects the presence and absence or distance of metals, and should be located where the rotational process can be appropriately monitored.
- Install Prox unit according to National Electrical Code and/or local standards.
- Seal all conduit entries to the enclosure.
- Close transparent cover immediately upon program completion to minimize exposure to dust and weather.
- Do not use this device in explosive areas or locations classified as Hazardous. Unit is not designated for NEMA 7,8,9 or 10 locations.

## PROX 120 SPEED SWITCH DIMENSIONAL DRAWINGS

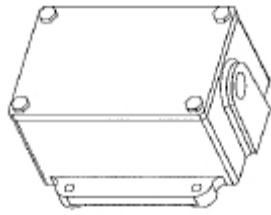

SCALE: 0.250

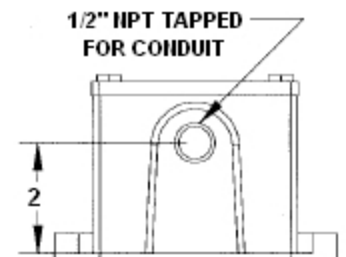
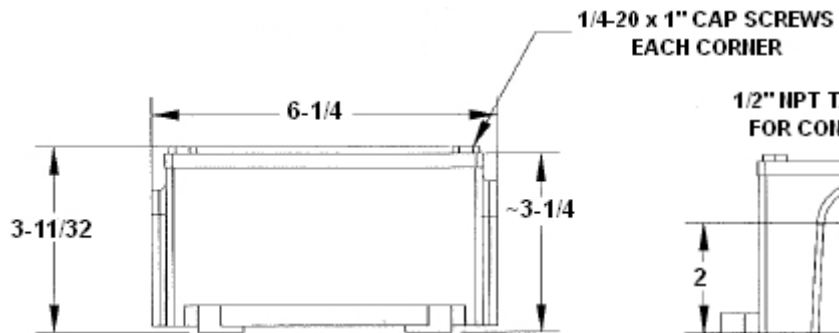
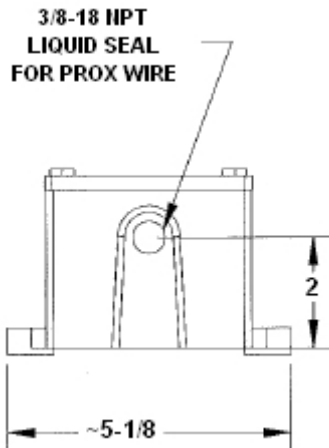
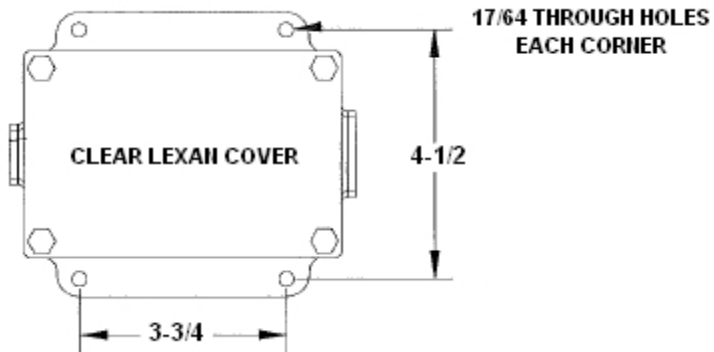

All measurements in inches.

### SPEED CONVERSIONS & RANGE CALCULATIONS

Operating range and conversion calculations from Hz to RPM are dependent upon the number of pulses per each revolution. With one pulse per revolution, 1 Hz is equal to 60 RPMs (one pulse per second X 60 seconds per min = 60 RPMs). Under-speed limit of 0.1 Hz equates to 6 RPMs.

Pulses may be manipulated by adding or subtracting vanes, bolt heads, spokes, holes, etc. in the monitoring device wheel or hub. The inductive proximity sensor detects ferrous (iron) metals best, but can also sense other metals. Sensing distance may vary depending on the metal and pulse vane configuration.

The Prox 120 comes with a 500Hz sensor.

### PROGRAMMING SPECS

**HSPD & LSPD:** High and Low Speed alarm settings are percentage variables, based on the normal calibrated running speed of 100%. The Under-Speed value range is 20-99% of Full Speed, while Over-Speed is 101-199%. Values outside this range will not be accepted.

**Start-Delay:** Programmable from 0 to 255 seconds, activated by initial power applied to the device. Delay will not re-occur until power is turned off and back on.

**Programming Setup:** INCR (Increment) and ENTER pushbuttons, and four character alphanumeric LED display along with STATUS and RELAY LEDs.

**Program Settings:** SDLY (Start-up Delay), LSPD and HSPD, RYFS (Relay failsafe condition), ADLY (Relay Energize Delay), CDLY (Relay De-energize delay), OKAY (Condition Indicator), ERR 0-9 (trouble shooting info).

**Relay Reaction Time:** Independently Programmable from 0 to 255 seconds. Energized ADLY and De-energized CDLY.

**Alarm Indicators:** The 4-character alphanumeric LED display provides <MIN low-speed alarm and >MAX over-speed display for alarm condition and ERROR codes for diagnostics. GREEN status LED provides pulse indication, RED relay LED indicates energized or de-energized condition of the relay.